AA-75CF

Portable Compressor

NSN: 6520-01-456-7170

COMMAND•AIR



**SERVICE MANUAL
& PARTS LIST**



TABLE OF CONTENTS

Maintenance and Servicing Instructions . . .	3
Cleaning and Lubrication	3
Performance Verification	3
Inspection	3
Troubleshooting	3-4
Disassembly, Repair, Replacement, Reassembly, and Check Out	4-12
Compressor Chassis Removal	4
Compressor Removal	6
Compressor Motor Service Kit Installation	8
Aftercooler Fan Replacement	8
Aftercooler Assembly Replacement	9
Pressure Switch Replacement	10
Check Valve Replacement	10
Removing the Air Storage Tank	10
Replacing Pneumatic Tubing	11
Removing Electronics Module	12
Removing the Intake Fan	12
Transformer Replacement	12
Parts List	14-26
Case Base	14
Case Top, Inside	14
Case Top, Outside	14
Compressor Chassis	16
Air Storage Tank	16
Transformer	18
Compressor	18
Intake Fan	20
Aftercooler	20
Motor Exhaust	22
Electronics Module	22
Pressure Switch	22
Top Cover	24
Expendables	26

Table of Illustrations

Figure A: AA-75CF Component Identification	5
Figure B: Compressor Chassis Removal . . .	5
Figure Group C: Compressor Removal . . .	6
Figure D: Service Kit Installation	7
Figure E: Aftercooler Removal	9
Figure F: Pressure Switch Leads	11
Figure G: Tank Removal	11
Figure H: Intake Fan Removal	12
Figure I: Electronics Module	12
Figure J: AA-75CF System Wiring Schematic	13
Figure K: AA-75CF System Pneumatic Schematic	13
Figure 1: Case Base	15
Figure 2: Case Top, Inside	15
Figure 3: Case Top, Outside	15
Figure 4: Compressor Chassis	17
Figure 5: Air Storage Tank	17
Figure 6: Transformer	19
Figure 7: Compressor	19
Figure 8: Intake Fan	21
Figure 9: Aftercooler	21
Figure 10: Motor Exhaust Chassis	23
Figure 11: Electronics Module	23
Figure 12: Pressure Switch	23
Figure 13A & B: Top Cover	25

Maintenance and Servicing Instructions

Cleaning and Lubrication

Exposed surfaces of the AA-75CF should be disinfected with a commercial dental disinfectant. Abrasive cleaning agents have the potential to damage surface finishes and should be avoided. To minimize the risk of corrosion do not use chlorinated solvents to clean either the inside or the outside of the compressor valves, the air storage tank or the aftercooler assembly.

Lubrication of AA-75CF compressor components is unnecessary. The compressor uses sealed bearings and Teflon cylinder technology to eliminate the need for lubrication. The cooling fans similarly use sealed bearings.

Performance verification

To verify proper compressor function, make sure the tank gauge pressure is at zero, the tank drain valve is closed and the pressure switch is in the OFF position. Plug the compressor into the power source. Switch the pressure switch to the AUTO position. The compressor should charge the air storage tank and the intake and aftercooler fans should run. Confirm that compressor shut off occurs at approximately 105 psi. Open the tank drain valve. When gauge pressure in the tank drops below 70 psi, the compressor should restart. Allow the tank to drain until all significant water is removed. Once the air exiting the tank is dry to the touch, close the tank drain valve. When compressor cuts off, verify that the fans continue to run for approximately two minutes and that the tank pressure remains constant near 100 psi. A 5 psi drop can be expected after cut off. Listen for leaks at pneumatic system connections. If leaks are indicated by pressure loss but are not audible, check the seals with a soap test. A water-liquid detergent solution should be applied to the circumference of the joint. A leak at a seal will cause the solution to bubble. Tighten the joint, if necessary reapply Teflon tape, until bubbles no longer appear.

Inspection

The felt media of the air intake filters requires periodic inspection and replacement. Initial inspection is recommended after 500 hours. Afterwards a service duration should be determined based on the operating conditions. Excessive felt contamination can reduce compressor output and may affect service life.

Initial compressor inspection is recommended at 2,000 hours. The wear of the rider ring is an indication of the general condition of the compressor rings. To inspect the rider rings, remove the compressor from the case as per Compressor Removal instructions, then disassemble the compressor cylinder heads. If the rider ring measures 0.055 in. or less, an overhaul should be performed by installing a Service Kit. See the Compressor Motor Service Kit Installation subsection of the Disassembly, Repair, Replacement, Reassembly and Check Out Section of this manual for detailed installation procedures.

Troubleshooting

Symptom	Problem	Action
System non-operational	Main breaker tripped Pressure switch contacts corroded	Reset main breaker Replace switch
Compressor motor not running	Main breaker tripped Thermal overload tripped	Reset main breaker Allow several minutes to cool and restart
No duplex outlet power	Circuit breaker tripped	Reset duplex breaker
Tank pressure exceeds 110 psi.	Pressure switch settings altered	Readjust according to Pressure Switch Replacement section note
Compressor attempts to restart under load	Leaking or obstructed check valve Misaligned unloader valve	Disassembly and clean or replace. Tighten unloader valve screw and realign.
Extended compressor cycle time	Air demand has been altered Clogged intake filters. Air line leaks. Water collected in air storage tank.	Readjust instruments Clean or replace. Tighten couplings, retape. Blow off tank

Motor won't start with gauge pressure at 0 psi

The thermal protection of the compressor may have been activated. If system fans are still functioning, allow the unit to cool briefly and restart. If system fans are not running, a high amperage condition existed resulting in the system circuit breaker being tripped. This condition will result from a leaking check valve or malfunctioning unloader valve.

Motor experiences labored start with gauge pressure below 70 psi

This condition results from the motor attempting to restart with pressure in the cylinder. This is an indication of a leaking check valve or malfunctioning unloader valve. Inspect the check valve and the unloader switch. Service components as required.

Motor starts at an intermediate pressure or Pressure relief valve is activated

Disconnect the unit from the power source. Inspect the pressure switch for excessive wear and damaged or dirty components. Replace parts as required.

Compressor cycles more frequently than is common

Shut off compressor. Watch the tank pressure gauge. If the tank pressure drops rapidly, check tubing and fittings for leaks. If tubing and fittings are satisfactorily connected, the check valve should be inspected for dirt and damage. If after shut off tank pressure is maintained, the tank should be blown off. Water vapor can condense in the tank and reduce its capacity.

Compressor takes longer to build tank pressure than is common

Check system tubing and fittings for leaks. Inspect compressor air intake filters. Replace filter cartridge if required.

No power to duplex outlet

Verify system is powered. Reset duplex outlet circuit breaker.

Disassembly, Repair, Replacement, Reassembly and Check Out

The AA-75CF has been designed for minimal required maintenance. Compressor service should be performed every two thousand hours and component service should be required only when component damage occurs or service life is exceeded. Modular construction makes component inspection and replacement simple. Maintenance can be performed with only the following tools: a 7/16 socket drive, a set of English Hex wrenches, a 12 in. and an 8 in. crescent wrench, flathead and #2 Phillips screwdrivers, and a 1/4 inch open face wrench.

For Reassembly, Teflon tape or an equivalent thread sealant should be applied to all pneumatics fittings and a serviceable thread locking compound should be applied to all fasteners.

To check the success of any repair, perform the procedure detailed in the Performance Verification section.

The first step in any major component replacement is the removal of the compressor chassis from the case bottom.

Compressor Chassis Removal

Tools: 7/16 in. socket wrench and serviceable thread locking compound.

1. Remove case top.
2. Carefully place unit top cover down.
3. Remove the case bumper screws, sealing washers and case bumpers. *Reference Figure B*
4. Lift off case bottom. Use a rocking motion to clear ID plate rivets.
5. Replace by reversing steps. Secure case bumper screws using thread locking compound.

Figure A
AA-75CF Component Identification

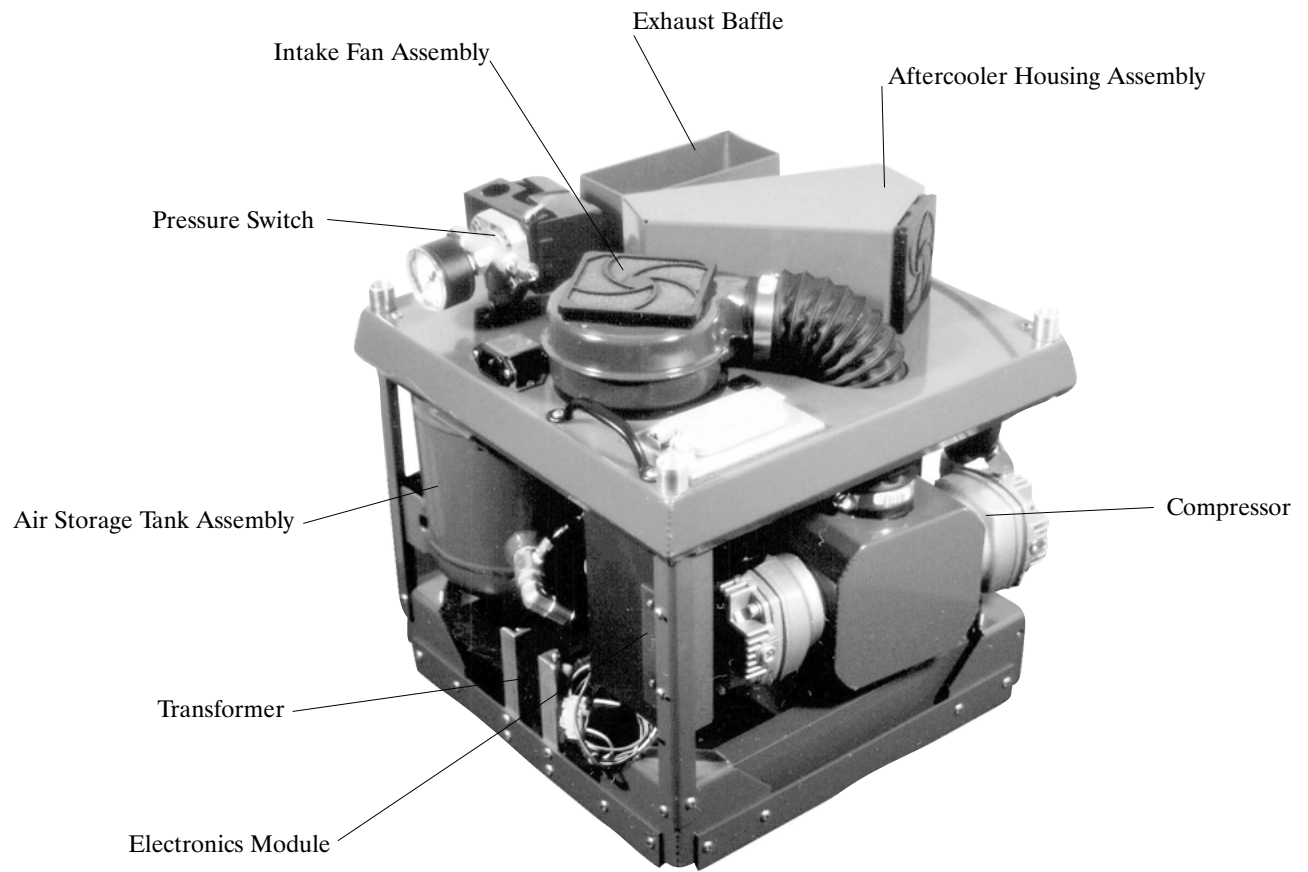
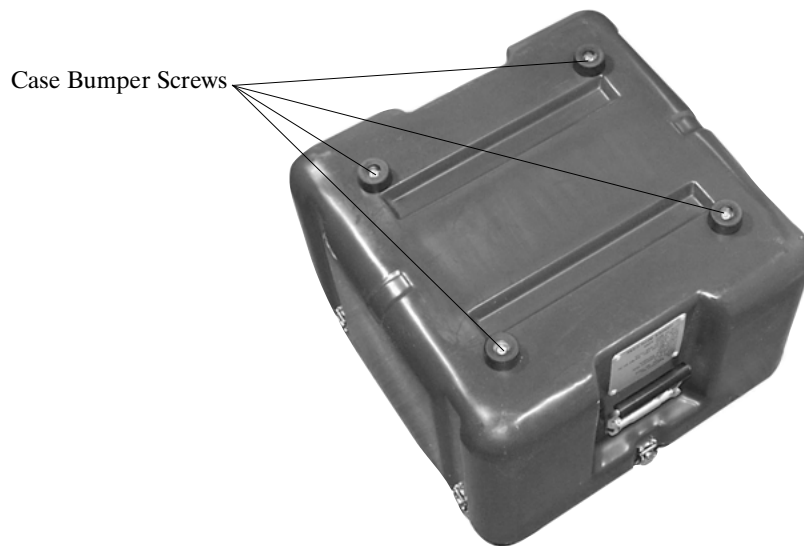

Figure B
Compressor Chassis Removal



Compressor Removal Reference Figure Group C

Tools: 1/4 and 5/16 hex drive or Allen wrench, flat head screwdriver, 12 in. or smaller crescent wrench, pliers, and 1/4 open face wrench.

1. Remove compressor chassis from case bottom as per the Compressor Chassis Removal section.
2. Loosen the duct clamp at on the motor side of the intake hose and remove the hose from the motor intake.
3. Loosen the nut on the motor tee fitting and remove the 1/2 tubing.
4. Disconnect the ground wire from under the capacitor cover.
5. Loosen the exhaust duct and twist it free from of the compressor.
6. Disconnect the five insulated terminals from the back of the compressor.
7. Disconnect the two inline connectors.
8. Place the compressor chassis on its right side (motor intake down).
9. Remove the four motor mount bolts.
10. Lift the compressor chassis off of the free compressor.
11. Repair and reassemble by reversing steps. Replace motor connections in their original locations. See figure C or Figure I System Wiring Diagram. Note: There are two possible terminal locations at 1 and 5. Either location is acceptable.

Figure Group C
Compressor Removal

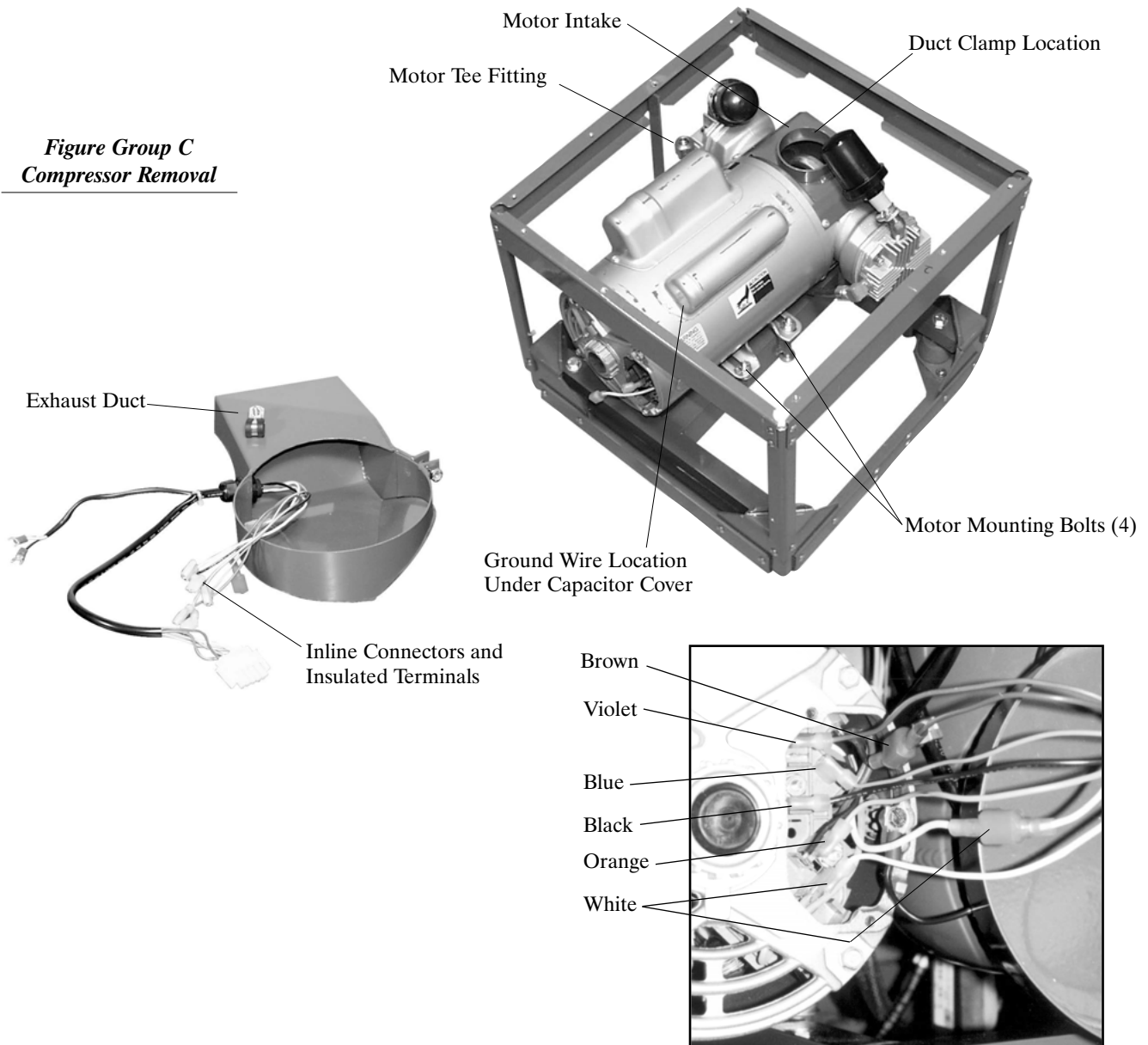
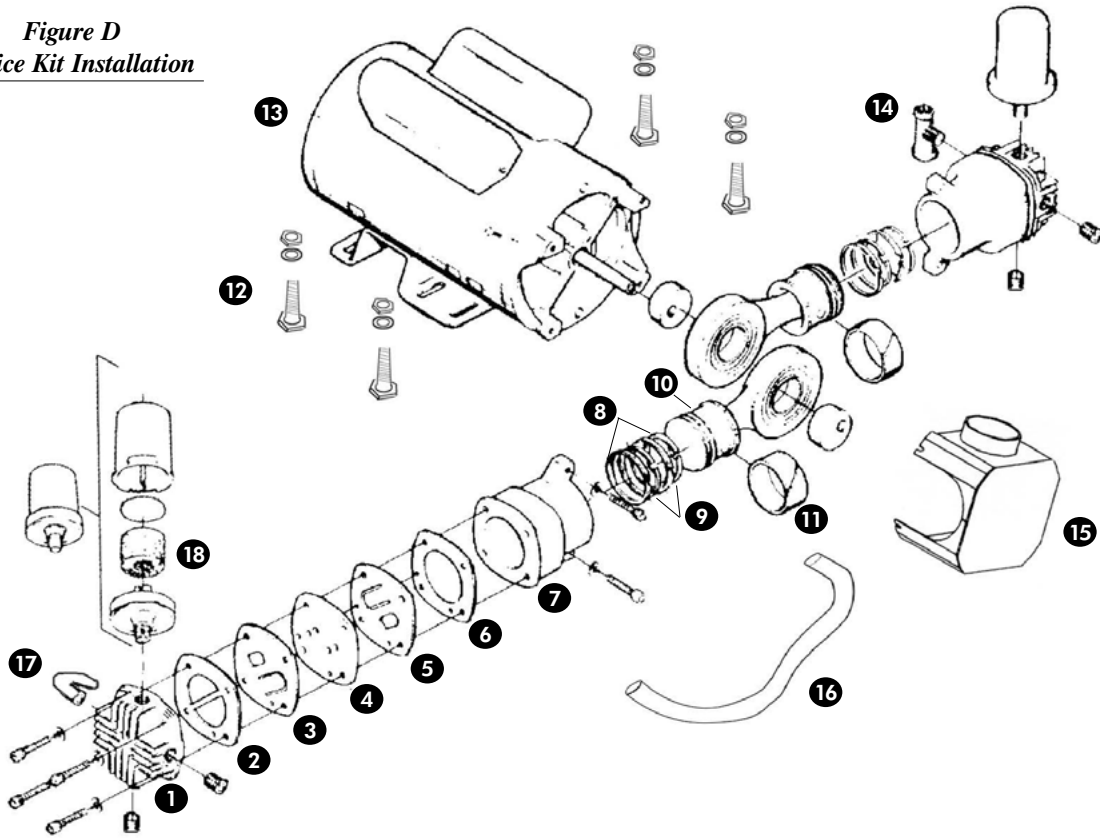

Figure D
Service Kit Installation



ITEM	PART NUMBER
① Cylinder Head	Included With Motor
② *Head Gasket	Service Kit
③ *Outlet Valve	Service Kit
④ Plate Valve	720015
⑤ *Inlet Valve	Service Kit
⑥ *Cylinder Gasket	Service Kit
⑦ Cylinder	720015
⑧ *Piston Ring	Service Kit
⑨ *Piston Seal	Service Kit
⑩ Piston Rod Assembly	720015
⑪ *Rider Ring	Service Kit
⑫ Motor Mount Bolt, Nut, Washer	Commercial
⑬ Motor	720015
⑭ Motor Tee Fitting	730358
⑮ Motor Intake Assembly	460784-08
⑯ Crossover Tube	460777-08
⑰ Motor Elbow Fitting	730357
⑱ *Felt	Service Kit
⑲ Service Kit	730383

* Denotes parts included in the Service Kit.

Compressor Motor Service Kit Installation *Reference Figure D*

(Adapted from Gast Operation & Maintenance Technical Manual).

The compressor motor service kit contains the following: Head Gasket, Valves, Cylinder gasket, Piston Rings, Piston Seals, Rider Ring, and Felts.

Dis-Assembly

Tools: 3/16, 1/4, and 5/16 hex drive or Allen wrench, flat head screwdriver, 12 in. or smaller crescent wrench, pliers, and 1/4 open face wrench.

1. Disconnect the compressor from the electrical power.

! CAUTION ! You must disconnect the pump from electrical power before servicing it. Failure to do so can result in severe personal injury or death.

2. Drain the air storage tank and turn the pressure switch to the OFF position.

! CAUTION ! You must vent all air lines to the compressor to remove pressure before servicing. Failure to do so can result in severe personal injury.

3. Remove the unit from the case bottom and the compressor from the compressor chassis as described in the Compressor Chassis removal and Compressor Removal subsections above .

4. Remove the motor intake and the crossover tube from the compressor.

5. Remove the cylinder heads, and valve components. **DO NOT** re-arrange or reorient the valve components.

6. Remove the cylinder and rings.

Make sure all compressor parts are clean before reassembling. **DO NOT** use any chlorinated solvents to clean valves, or any liquids to flush units. The stainless steel valves may be cleaned with water. All parts, except the valves, can be cleaned with any industrial, non-flammable, non-toxic, non-petroleum based cleaning solvent.

Assembly

1. Install piston seals, piston rings, and rider ring on each piston.

2. Locate ring joints approximately opposite each other.

3. Finger tighten the cylinders to the bracket with the cylinder screws and washers.

4. With the piston in its top dead center position, adjust each cylinder flush with top of piston and torque cylinder screws to 150-160 inch lbs. Re-torque second time.

5. Stack the valve components in order as originally assembled.

6. Install the cylinder head and head screws.

NOTE: The exhaust ports in the cylinder heads have been marked by omitting the ends of two of the fins.

7. Torque all head screws 150-160 inch lbs.

8. Turn the motor shaft by hand at this point to ensure that the rod assembly is not hitting the head.

NOTE: If rod assembly does hit head, loosen cylinders and re-adjust.

9. Replace the motor intake and crossover tube.

10. Re-torque head screws again after running for 10 minutes.

Replacing Aftercooler Housing Parts *Reference Figure E*

Aftercooler Fan Replacement

Tools: 1/8 hex drive or Allen wrench, #2 Phillips screwdriver, 12 in. or smaller crescent wrench, and thread locking compound.

1. With compressor chassis extracted remove the five aftercooler housing bolts from the top cover.

2. Lift aftercooler housing and disconnect the fan plug.

Figure E - Aftercooler Removal

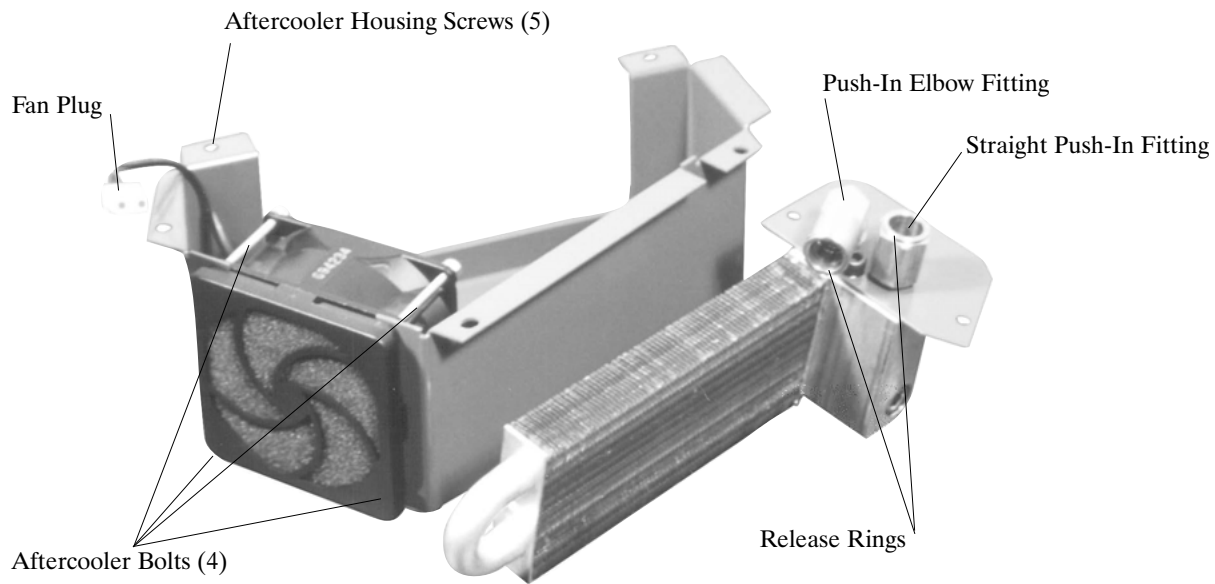

3. Remove media guard and media from the fan guard assembly.
4. Remove the four aftercooler fan bolts.
5. Replace aftercooler fan and reassemble by reversing steps. Secure aftercooler housing bolts with thread locking compound.

Aftercooler Assembly Replacement Reference Figure E

Tools: 1/8 and 3/16 hex drive or Allen wrench, flathead screwdriver, 12 in. or smaller crescent wrench, serviceable thread locking compound and Teflon tape.

1. Remove compressor chassis from case bottom as per the Compressor Chassis Removal section.
2. Loosen the nut of the motor tee fitting which secures the motor/aftercooler tube. Remove the tubing from the motor tee fitting leaving the nut and ferrule on the tube. Reference Figure Group C
3. Depress the release ring on the aftercooler push-in elbow then pull free the motor/aftercooler tube previously loosened in step 2.
4. Remove the tank/aftercooler tube from the push-in elbow fitting on the tank by depressing the release ring and pulling on the tube. Note the tube routing.
5. Rotate the compressor chassis onto its left side (motor exhaust side). Depress the release ring on the push-in straight fitting at aftercooler and pull tube straight out.
6. Remove the five aftercooler housing screws, disconnect fan plug and remove aftercooler housing.
7. Slide the aftercooler toward the compressor chassis front (power inlet) and remove.
8. Clamp aftercooler block in vise and remove push-in fittings, straight fitting first, then elbow. Remove aftercooler manifold block screw and aftercooler cover plate. Minimize handling of the aftercooler to avoid cracking it.
9. Replace aftercooler assembly and reassemble by reversing steps, being careful to reroute tubing as noted during removal. Seal threaded ends of aftercooler push-in fittings with Teflon tape or sealing compound and secure aftercooler housing bolts and aftercooler cover plate bolt with a serviceable thread locking compound.

Replacing Air Storage Tank Components

Pressure Switch Replacement *Reference Figure F*

Tools: 1/8 hex drive or Allen wrench, #2 Phillips screw driver, 12 in. or smaller crescent wrench, thread sealing compound or Teflon tape.

1. Unplug the AA-75CF compressor and drain the air storage tank.
2. Remove compressor chassis from case bottom as per the Compressor Chassis Removal section.
3. Remove four exhaust baffle screws to allow access to the pressure switch screws.
4. Loosen pressure switch cover screw and remove pressure switch cover.
5. Loosen the unloader valve nut and remove unloader tube.
6. Loosen screws on the pressure switch to release the motor power leads, the control wire leads and the switch ground.

When replacing leads, be sure the wire pair leading through the motor exhaust chassis to the motor connects to the MOTOR location on the pressure switch and that the wire pair from the control wire set, contained in polyester braid, connects to the LINE location of the pressure switch. Similar wire colors should attach on the same side of the pressure switch.

7. Remove pressure relief valve, female quick connect fitting, and pressure gauge.
8. Using the hex of the coupler fitting, turn pressure switch off of the air storage tank. Guide wires slowly through the 5/8 grommet during the initial turn.
9. Remove the coupler fitting from the pressure switch.
10. Replace pressure switch and reassemble by reversing steps. Use Teflon tape to seal pipe threaded fittings.

Note: In addition to exposing wire connections, removing the pressure switch cover exposes a pair of adjustment screws used to control the AA-75 CF compressor's cut off pressure and pressure range. By turning the metal screw clockwise the air storage tank cut off pressure is increased. Turning the plastic screw clockwise increases the separation between the cut off and cut in pressure. Air storage tank pressure should never be adjusted to exceed 110 psi.

Check Valve Replacement *Reference Figure G*

Tools: 12 in. or smaller crescent wrench, Teflon tape or thread sealing compound.

1. Remove compressor chassis from case bottom as per the Compressor Chassis Removal section.
2. Loosen nuts on 1/8 poly fittings and disconnect unloader tube and tank side tank drain tube.
3. Push in the release ring of the push-in elbow fitting on the tank then pull tank/aftercooler tube loose.
4. Remove push-in elbow fitting and 1/8 tube fitting from the check valve.
5. Remove check valve from the air storage tank.
6. Replace check valve and reassemble by reversing steps. Use Teflon tape to seal pipe threaded fittings.

Removing the Air Storage Tank *Reference Figure G*

1. Remove compressor chassis from case bottom as per the Compressor Chassis Removal section.
2. Complete Pressure Switch Replacement procedure omitting steps 7, 9 and 10.
3. Complete Check Valve Replacement procedure omitting steps 4 and 6.
4. Remove three tank assembly screws and the 1/8 tube fitting on the tank bottom.
5. Rotate the air storage tank slowly clockwise and remove through the exhaust duct side of the compressor chassis leading with the tank bottom.

Figure F
Pressure Switch Leads

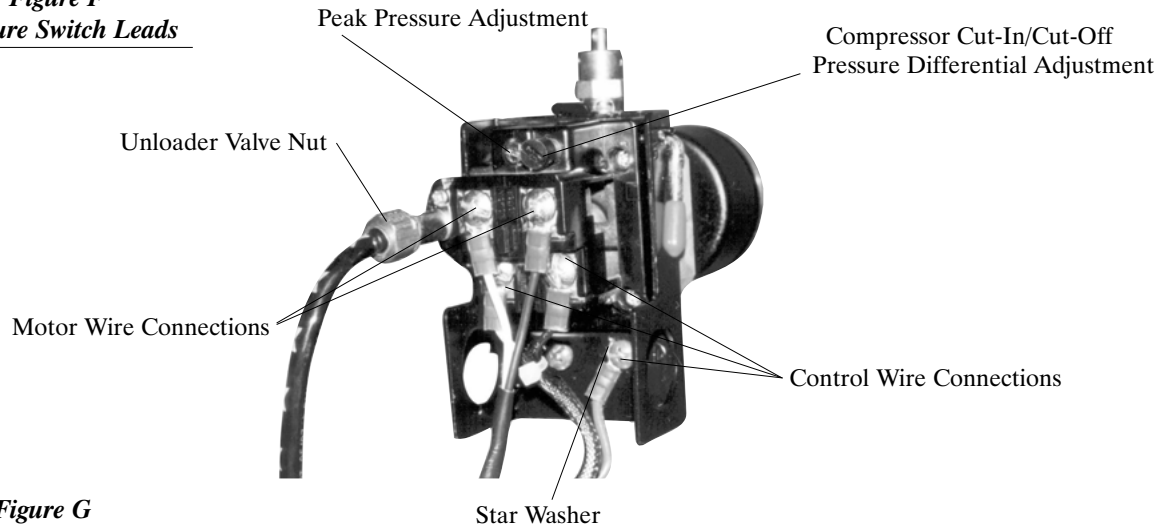
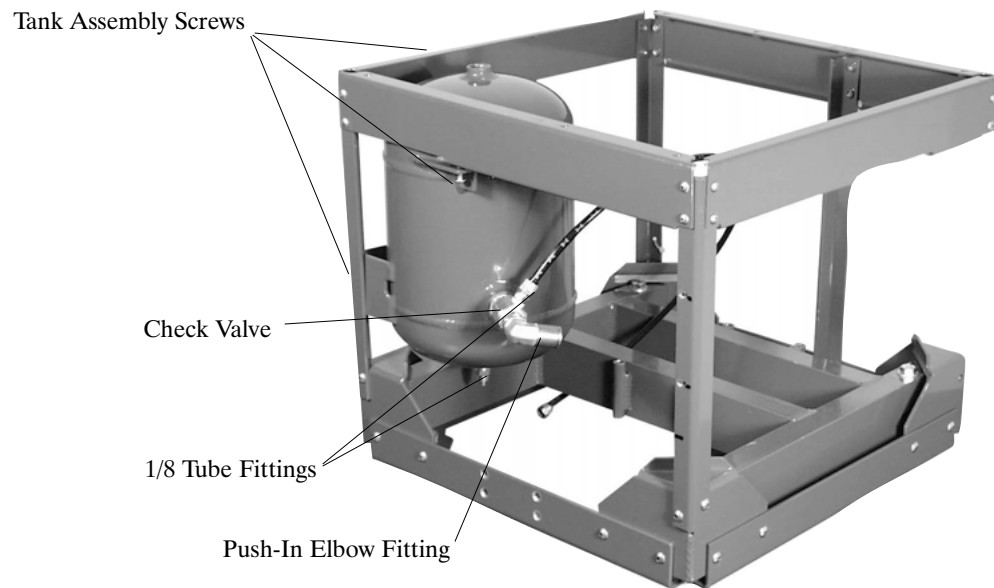

Figure G
Tank Removal



Replacing Pneumatic Tubing

1. Loosen tube at both ends by depressing the push-in fitting release ring then the tube free or by removing the fitting nut.
2. Note the ferrule type on both ends of the tube then discard tube section and attached ferrules.
3. Select the correct tubing size and cut to the appropriate length:

Motor / Aftercooler tube	13.0 in.
Tank / Aftercooler tube	8.1 in.
Unloader tube	10.0 in.
Case side tank drain tube	15.0 in.
Tank side tank drain tube	24.0 in.
Case drain tube	15.5 in.

4. Slide the fitting nut and the appropriate new ferrule onto the tube and re-attach. When replacing tubing routed to the aftercooler, make aftercooler connections first.

Removing the Electronics Module *Reference Figure I*

Tools: 1/8 hex drive or Allen wrench and serviceable thread locking compound.

1. Remove compressor chassis from case bottom.
2. Uncouple control wire set connector and motor wire set connector.
3. Remove the two electronics mounting screws.
4. Reattach by reversing steps. Install fasteners using a serviceable thread locking compound.

Figure H Intake Fan Removal

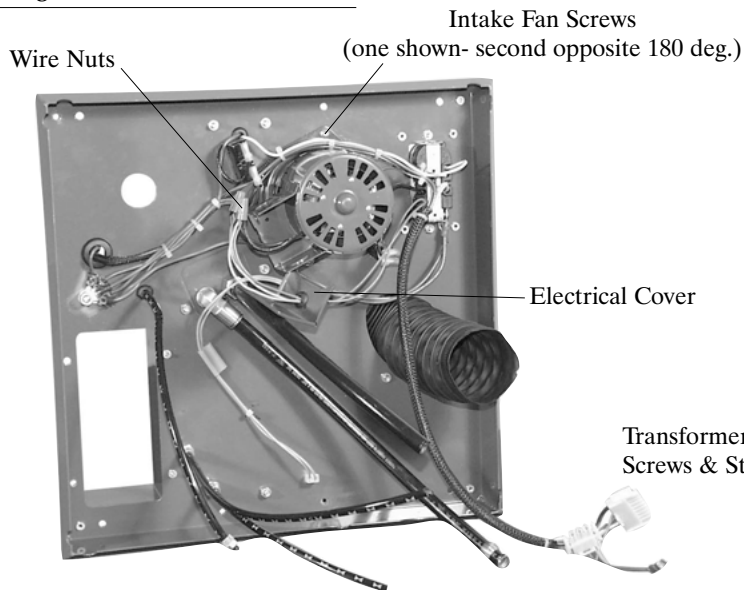
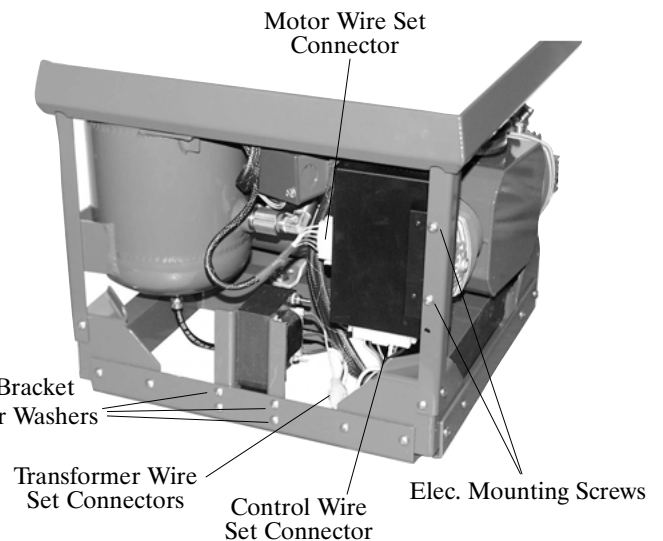

Figure I Electronics Module



Removing the Intake Fan *Reference Figure H*

Tools: 1/8 hex drive or Allen wrench, flat head screwdriver, side cutters and serviceable thread locking compound.

1. Remove compressor chassis as per the Compressor Chassis Removal section.
2. Remove the 9 perimeter screws of the top cover.
3. Remove pneumatic tubing at tank elbow push-in fitting, motor tee fitting and tank drain poly fitting.
4. Lift off the top cover.
5. Remove the electrical cover on the fan motor to expose the electrical connections
6. Remove the two wire nuts and pull the two wire pairs through the 1/4 grommet.
7. Remove the two intake fan screws located on the underside of the top cover.
8. Remove the fan motor being careful not to bend the impeller.
9. Replace intake fan and reattach by reversing steps. Install fasteners using a serviceable thread locking compound. Strip wires 1/4 in. and reconnect using wire nuts. Connect one orange and one purple wire to each black fan lead. Individual wire orientation is not critical.

Transformer Replacement *Reference Figure I*

Tools: 1/8 hex drive or Allen wrench and thread locking compound.

1. Remove compressor chassis from case bottom.
2. Uncouple the connector between the transformer and the electronics box.
3. Remove the four transformer bracket screws.
4. Replace and reassemble by reversing steps. Apply thread locking compound to screws when installing. Be sure star washers are replaced under the bolt heads contacting the brackets and between the brackets and the chassis base.

Note: To check the success of any repair perform the procedure detailed in the Verification section.

AA-75CF SYSTEM WIRING SCHEMATIC

Figure J

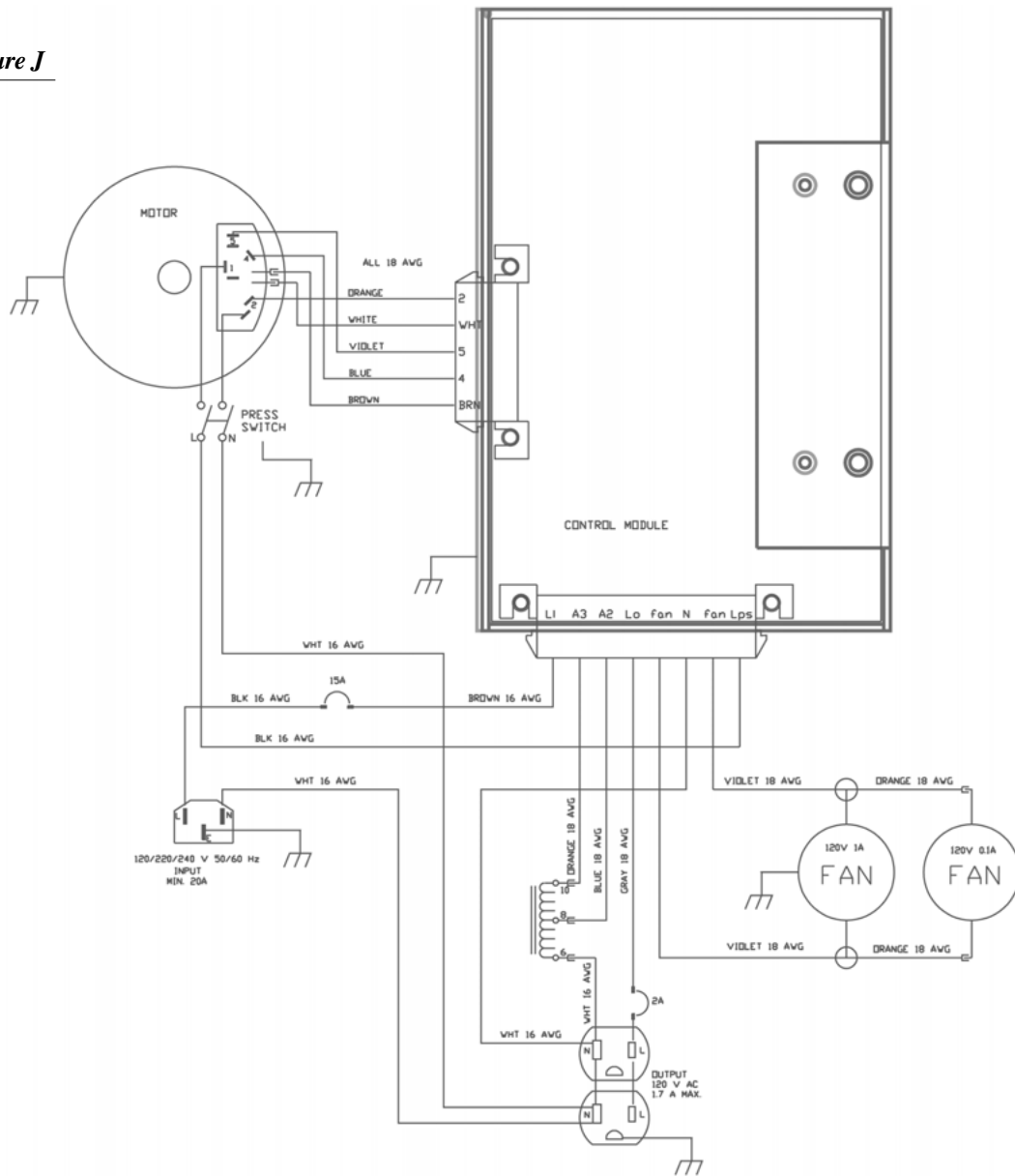

AA-75CF SYSTEM PNEUMATIC SCHEMATIC

Figure K

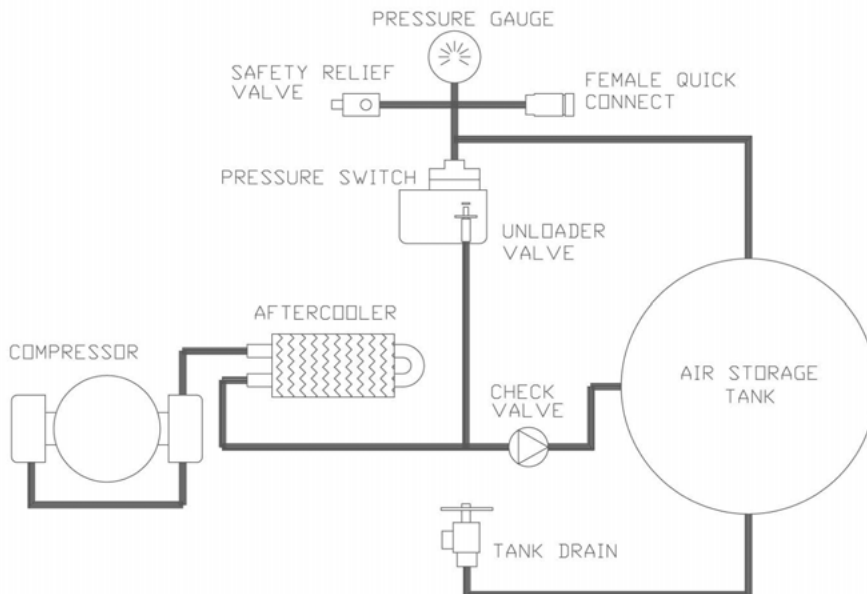

PARTS LIST

Reference Figure 1

ITEM	PART NUMBER	QUANTITY
① Case, Mil. Spec., Bottom	410128	1
② Identification Plate, Case	420229	1
③ Weather stripping	730375	63in.
④ Case Bumper	730109	4
⑤ SCREW, Hex head,Stnl, 1/4-20 x 1 1/4	Commercial	4

Reference Figures 2 & 3

ITEM	PART NUMBER	QUANTITY
① Case, Mil. Spec., Top	410128	1
② Case Leg	460776-08	2
③ Case Leg Pivot	460802-08	4
④ Case Leg Bumper	460828	4
⑤ NUT, Nylok, Stnl, 10-32	Commercial	4
⑥ 230V Power cord	840007	1
⑦ 120V Power cord	840049	1
⑧ Cord Pouch	460649-08	1
⑨ BOLT, Button head socket, Stnl,10-32 x 5/8	Commercial	4
⑩ Washer, Sealing, Stnl, #10	510353	4

Figure 1 Case Base

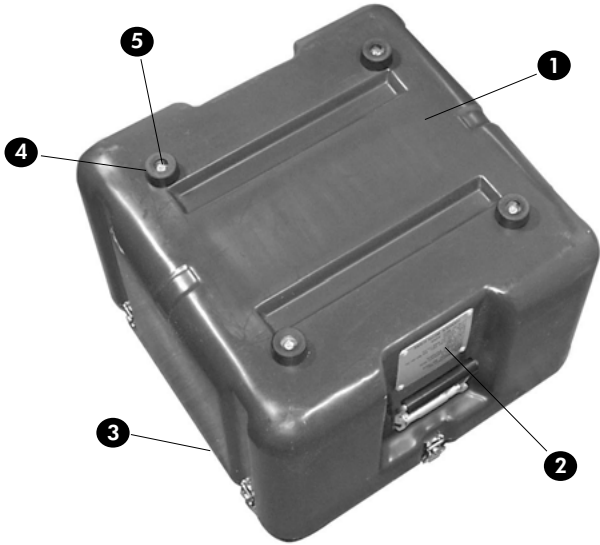

Figure 2 Case Top - Inside

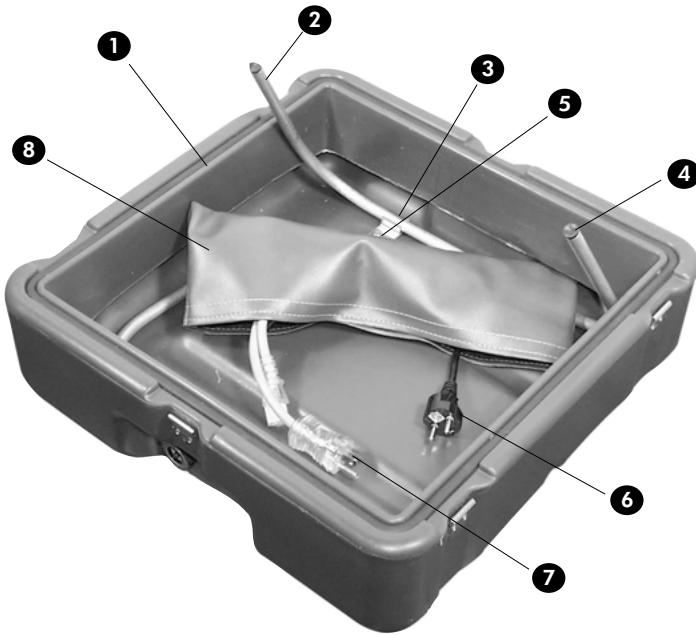

Figure 3 Case Top - Outside



Reference Figure 4

ITEM	PART NUMBER	QUANTITY
① Chassis Base	330260	1
② Vibration Isolator	730314	3
③ SCREW, Flathead Phillips, Stnl, 1/4-20 x 1/2	Commercial	6
④ Chassis Corner Bracket	330261	4
⑤ Motor Mount	330255-08	1
⑥ NUT, Serrated flange, Stnl, 5/16-18	Commercial	4
⑦ WASHER, Mil. Spec. 15795-812	Commercial	4
⑧ BOLT, Hex head, Stnl, 5/16-18 x 2	Commercial	4
⑨ Chassis Corner Angle	460747-08	3
⑩ Chassis Side Angle	460748-08	1
⑪ Chassis Cover Channel, Front	460787-08	1
⑫ Chassis Cover Channel, Left	460788-08	1
⑬ Chassis Cover Channel, Back	460789-08	1
⑭ Chassis Cover Channel, Right	460770-08	1
⑮ SCREW, Button head socket, Stnl, 10-32 x 3/8	Commercial	24
⑯ SCREW, Button head socket, 8-32 x 3/8	Commercial	16
⑰ WASHER, int. star, #10, stnl.	Commercial	24
⑱ WASHER, int. star, #8, stnl.	Commercial	16

Reference Figure 5

ITEM	PART NUMBER	QUANTITY
① Air Storage Tank	330254-08	1
② Check Valve	730332	1
③ FITTING, Brass, Push-In Elbow, 1/2 Tube x 1/4 MPT, Viton type	730359	1
④ FITTING, Brass, 1/4 Poly x 1/8 MPT	730117	2
⑤ TUBING, Air Brake, 1/4	730130	12.5 in.
⑥ SCREW, Button head socket, Stnl, 10-32 x 3/8	Commercial	3
⑦ WASHER, int. star, #10, stnl.	Commercial	3

Figure 4 Compressor Chassis

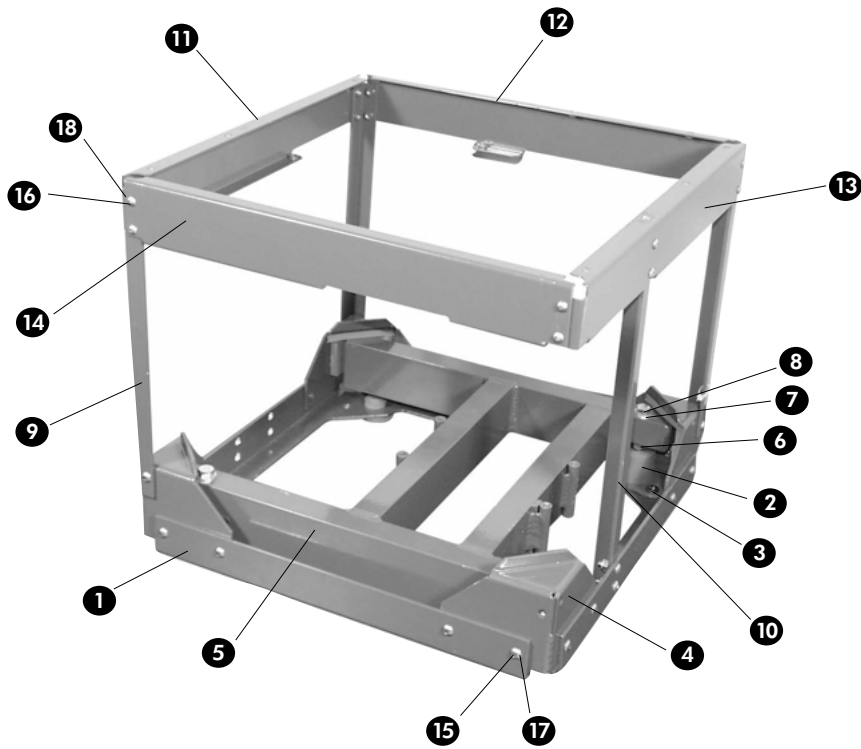
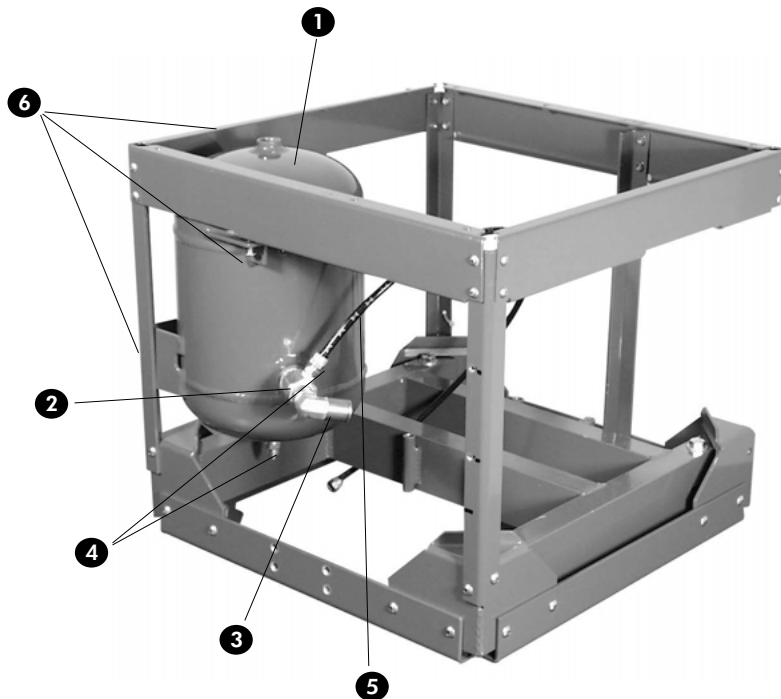

Figure 5 Air Storage Tank



Reference Figure 6

ITEM	PART NUMBER	QUANTITY
1 Transformer Assembly	875013	1
2 Transformer Bracket	460818-04	2
3 BOLT, Pan head Phillips, Stnl, 10-32 x 2	Commercial	4
4 NUT, Nylok, Stnl, 10-32	Commercial	4
5 SCREW, Button head socket, Stnl, 10-32 x 3/8	Commercial	4
6 WASHER, nylon, 0.062 thk	510019	2
7 WASHER, int. star, #10, stnl.	Commercial	6

Reference Figure 7

ITEM	PART NUMBER	QUANTITY
1 Compressor	720015	1
2 Motor Intake	460784-08	1
3 Crossover Tube	460777-08	1
4 FITTING, A/B branch tee, 1/2 tube x 1/4 MPT	730358	1
5 FITTING, A/B Male Elbow, 3/8 tube x 1/4 MPT	730357	1
6 FITTING, Plug, 1/4 MPT x 1/4 Hex countersink	730098	2
7 FITTING, 45 deg., 1/4 Flare x 1/4 MPT	730200	2
8 HOSE CLAMP, Marine grade, 7/16 - 25/32, Miniature width	510416	4
9 TUBING, 1/2" I.D. x 0.063 wall	AA-83A	1 in.
10 BOLT, Socket head, Stnl, 5/16-18 x 1 1/2	Commercial	4
11 WASHER, Mil. Spec. 15795-812	Commercial	4
12 NUT, Nyloc, Stnl, 5/16-18	Commercial	4
13 WASHER, int star, #8, stnl	510420	1

Figure 6 Transformer

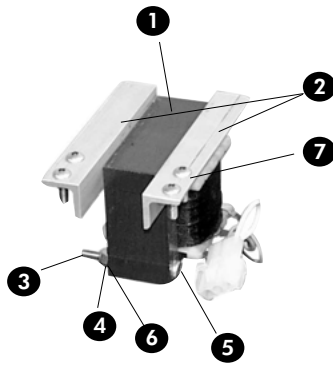
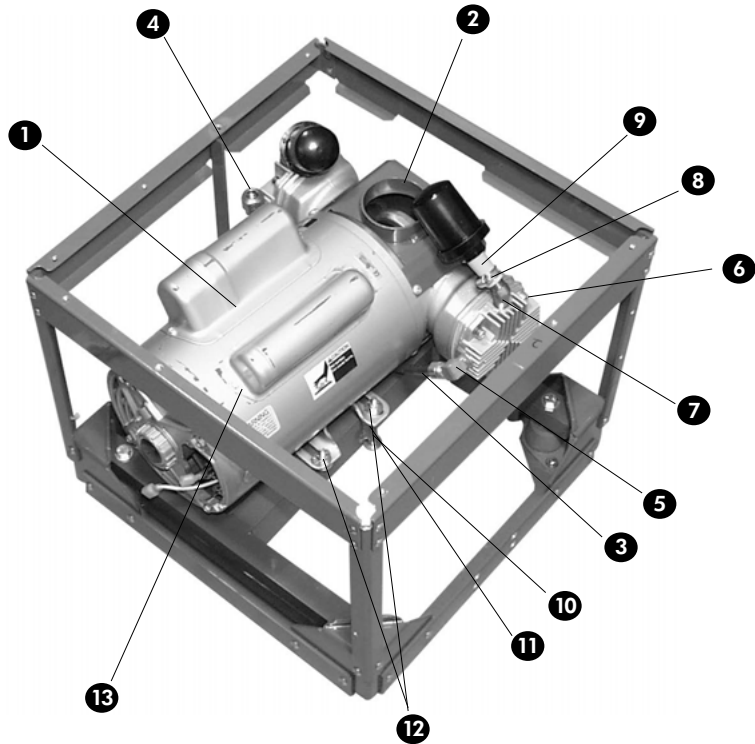

Figure 7 Compressor



Reference Figure 8

ITEM	PART NUMBER	QUANTITY
1 Intake Fan	330259	1
2 Intake Fan Gasket	460779	1
3 SCREW, Button head socket, Stnl, 10-32 x 5/8	Commercial	2
4 Intake Hose	730339	12 in.
5 HOSE CLAMP, Marine Grade, 1 13/16 - 2 3/4	510400	2
6 Intake Fan Filter Assembly	730334	1
7 BOLT, Flat head Phillips, Stnl, 6-32 x 1/2	Commercial	4
8 NUT, Nyloc, Stnl, 6-32	Commercial	4
9 1/4 Grommet	870185	1
10 WIRE NUT, Blue	Commercial	2
11 WASHER, #10 Ext Star, Stnl	510421	1

Reference Figure 9

ITEM	PART NUMBER	QUANTITY
1 Aftercooler Housing	460749-08	1
2 SCREW, Button head socket, Stnl, 10-32 x 3/8	Commercial	5
3 Aftercooler Fan	330264	1
4 Aftercooler Fan Filter Assembly	730333	1
5 BOLT, Flat head Phillips, Stnl, 6-32 x 2 1/4	Commercial	4
6 NUT, Nyloc, Stnl, 6-32	Commercial	4
7 Aftercooler Assembly	330257	1
8 Aftercooler Cover Plate	460793-08	1
9 SCREW, Socket head, Stnl, 1/4-20 x 3/4	Commercial	1
10 FITTING, Brass, Push-In Elbow, 1/2 Tube x 1/4 MPT, Viton type	730359	1
11 FITTING, Brass, Push-In Straight, 1/2 Tube x 1/4 MPT, Viton type	730361	1
12 TUBING, Air brake, 1/2 in.	730256	18.5 in
13 WASHER, int. star, #10, stnl.	Commercial	3

Figure 8 Intake Fan

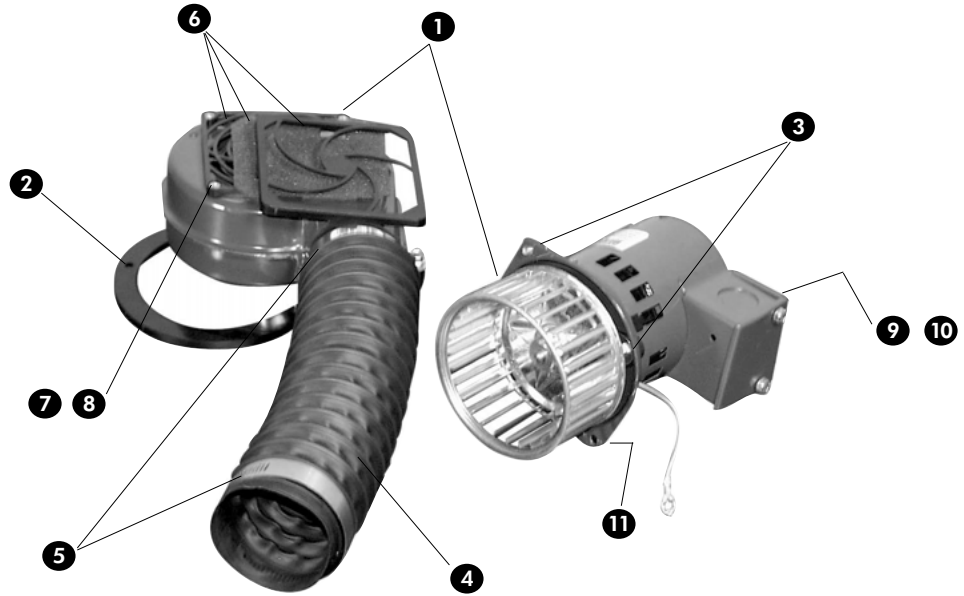
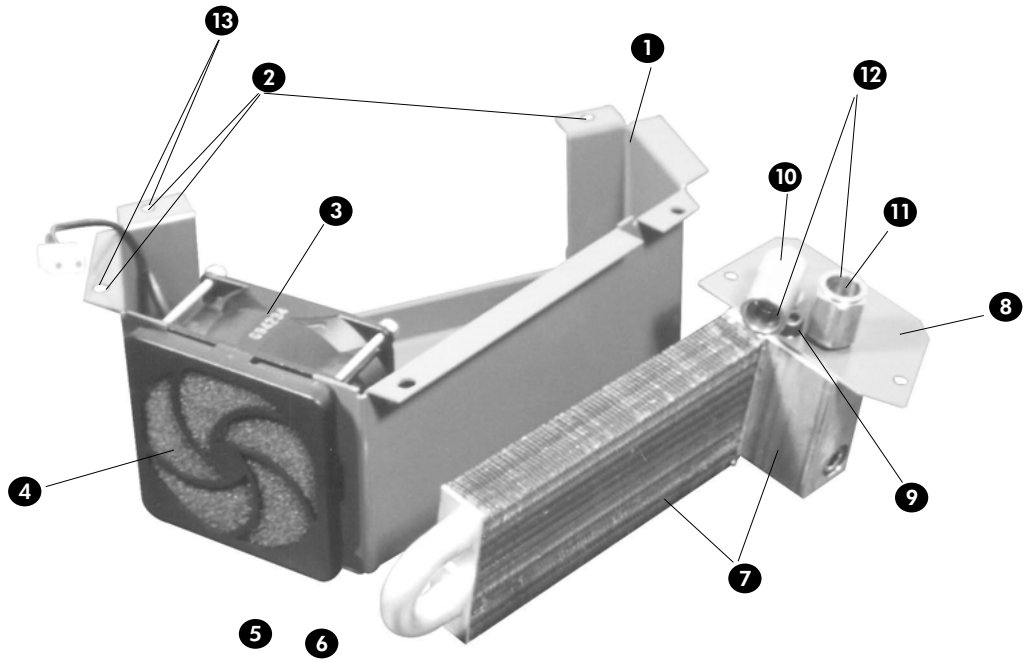

Figure 9 Aftercooler



Reference Figure 10

ITEM	PART NUMBER	QUANTITY
1 Motor Exhaust Chassis	330258	1
2 BOLT, Socket head, Stnl, 1/4-20 x 1 1/4	Commercial	1
3 NUT, Nyloc, Stnl, 1/4-20	Commercial	1
4 Motor Wire Set	875011	1
5 Motor Exhaust Strain Relief	840014	1
6 Strain Relief Nut	840015	1
7 Wire Clamp, Steel, Plated	510409	1
8 NUT, Nyloc, Stnl, 8-32	Commercial	1

Reference Figure 11

ITEM	PART NUMBER	QUANTITY
1 Electronics Module	330253	1
2 SCREWS, Button head socket, Stnl, 10-32 x 3/8	Commercial	2
3 WASHER, #6 Star Stnl.	510419	1
4 NUT, Nylok, Stnl. 6-32	Commercial	1
5 WASHER, int. star, #10, stnl.	Commercial	2

Reference Figure 12

ITEM	PART NUMBER	QUANTITY
1 Pressure Switch, 4 Port, Unloader	830052	1
2 7/8 Chrome Snapcap Hole Plug	510210	1
3 5/8 Grommet	870232	1
4 0-160 Pressure Gauge, 1/4 MPT	730136	1
5 FITTING, Quick disconnect, 3/8 Female x 1/4 MPT, w/ shut off	AA-63	1
6 FITTING, 1/4 x 1/4 MPT Coupler, Stnl	730097	1
7 Safety Relief Valve	730196	1
8 WASHER, #8, Ext Star, Stnl (Refer to Figure F, Page 11)	510420	1

Figure 10 Motor Exhaust Duct

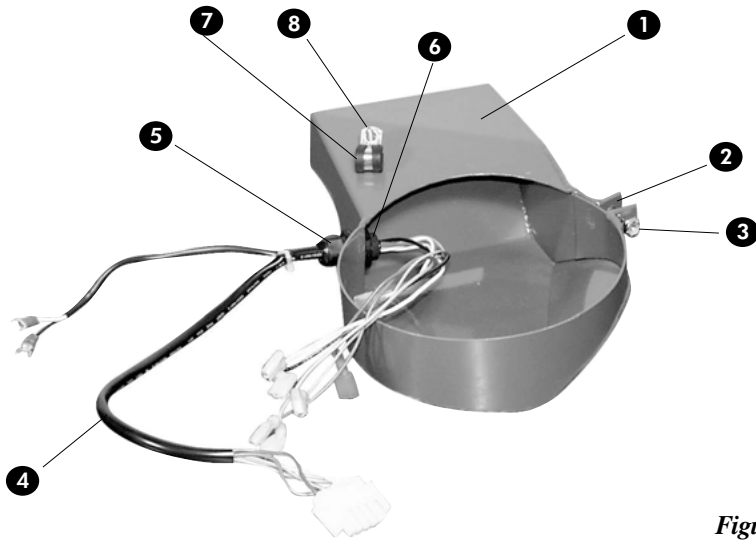

Figure 11 Electronics Module

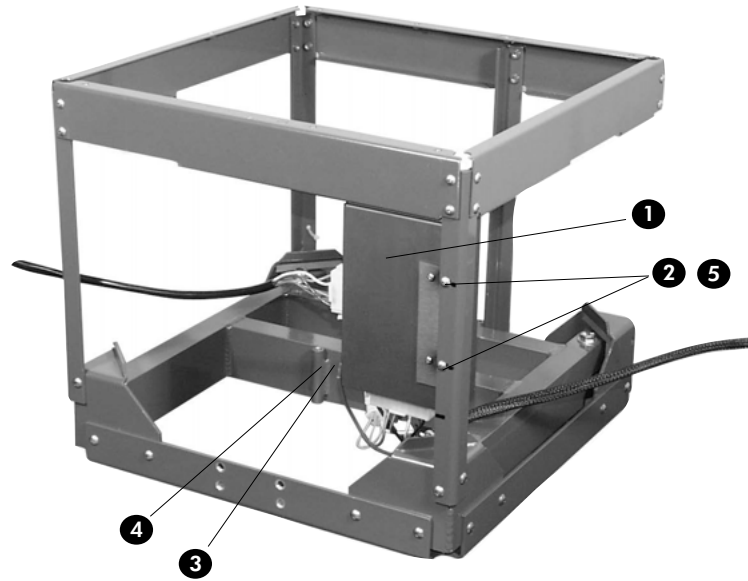
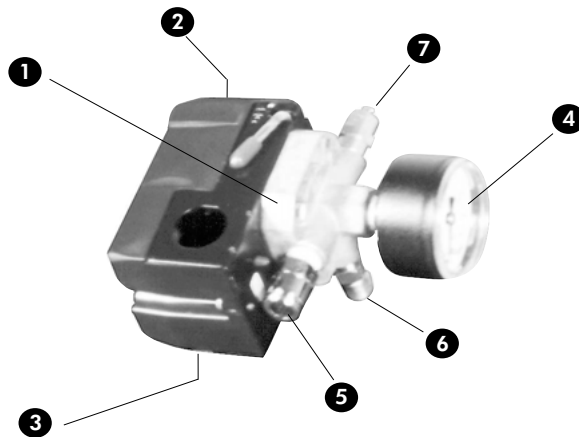

Figure 12 Pressure Switch



Reference Figures 13A & 13B

ITEM	PART NUMBER	QUANTITY
1 Top Cover	460746-08	1
2 Case Drain Fitting	730337	1
3 Tubing Support Sleeve	730095	1
4 TUBING, Air Brake, 1/4 in.	730130	54 in.
5 FITTING, Needle Valve, 1/8 MPT x 1/4 Poly Angle	730336	1
6 FITTING, Bulkhead mount, 1/8 FPT x 10-32	730307	1
7 FITTING, 10-32 x 1/4 Poly	730377	1
8 NUT, Wing, Brass, 1/4-20	Commercial	1
9 STUD, Brass, 1/4-20 x 1 1/2	Commercial	1
10 NUT, Jam, Brass, 1/4-20	Commercial	1
11 Duplex Outlet	840047	1
12 Outlet Cover	850039	1
13 SCREW, Pan head Phillips, Stnl, 6-32 x 3/8	Commercial	2
14 15A Circuit Breaker	830058	1
15 2A Circuit Breaker	830057	1
16 Power Connection Chassis	460798-08	1
17 SCREW, Flat head Phillips, Stnl, 6-32 x 3/8	Commercial	2
18 SCREW, Button head socket, Stnl, 10-32 x 3/8	Commercial	2
19 Leg Socket	460820-08	4
20 SCREW, Flat head Phillips, Stnl, 10-32 x 3/8	Commercial	4
21 Intake Hose Trim	730378	9.1 in.
22 1/4 Grommet	870185	2
23 5/8 Grommet	870232	1
24 Inlet Wire Set	875010	1
25 Control Wire Set	875012	1
26 Wire Clamp, Steel, Plated	510409	3
27 Wire Clamp, Nylon	510410	1
28 Wire Clamp, Self Adhering	860116	1
29 NUT, Nyloc, Stnl, 8-32	Commercial	4
30 Handle	850041	2
31 Exhaust Baffle	460771-08	1
32 SCREW, Button head socket, Stnl, 10-32 x 3/8	Commercial	10
33 WASHER, int. star, #10, stnl.	Commercial	4
34 Weather Stripping	730394	62 in.

Figure 13A Top Cover

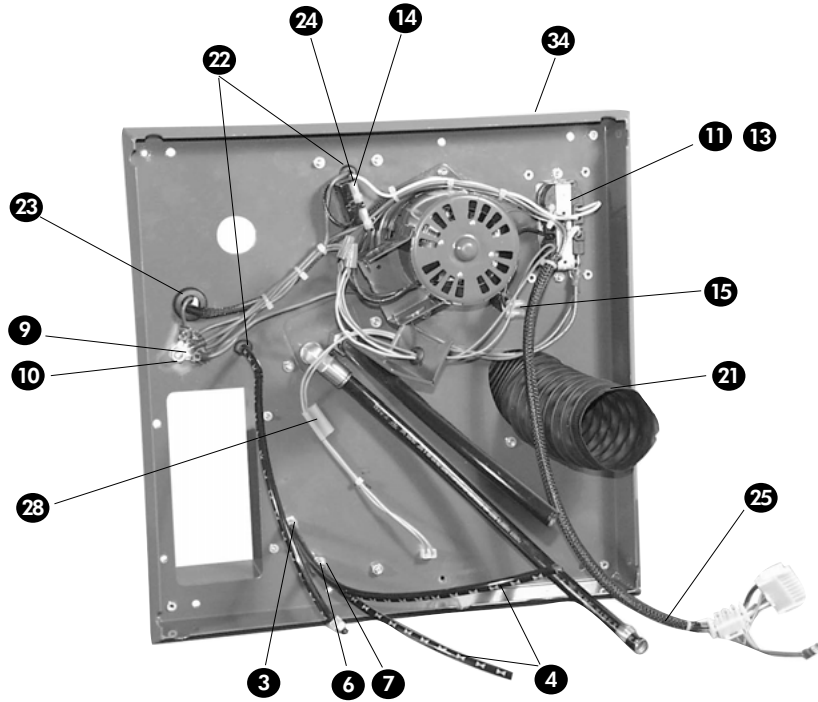
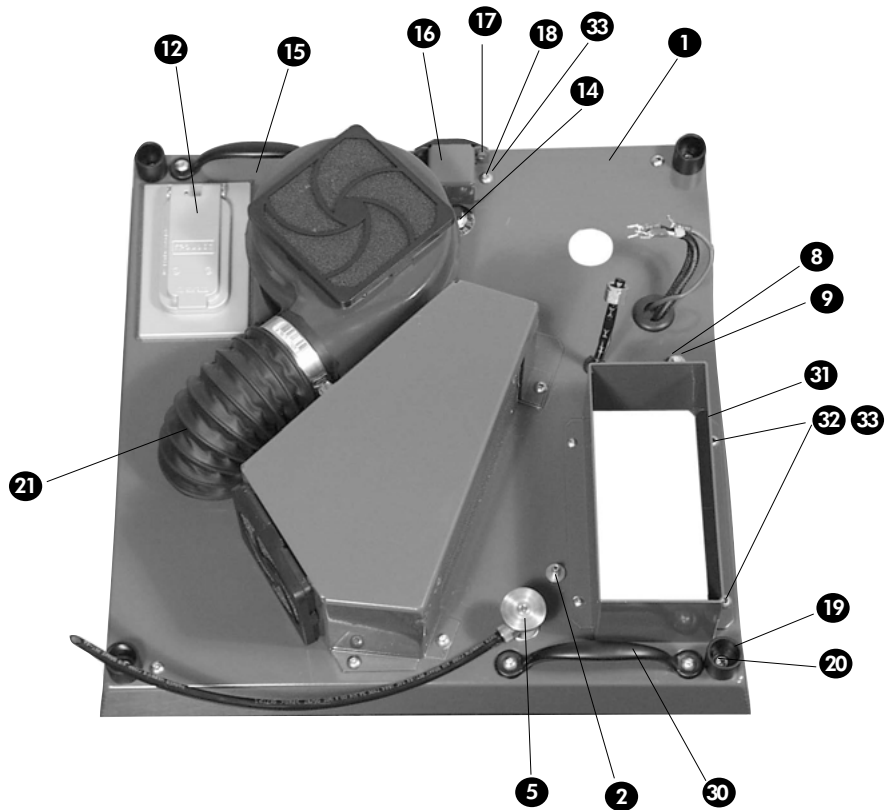

Figure 13B Top Cover



Expendables

ITEM	PART NUMBER
① Felt, Filter Media	730382
② Compressor Rebuild Kit	730383
③ Aftercooler Fan Filter Media	730380
④ Intake Fan Filter Media	730381

For Further Service And/Or Technical Assistance Contact:



*P.O. Box 1548 Woodinville, WA 98072-1548
1-800-426-5913 * 425-487-3157 * Fax: 425-487-2608
email: info@aseptico.com * Internet: www.aseptico.com*